

NO.	QTY.	DESCRIPTION	MODEL NUMBER			STANDARD SEAL KIT	FLUOROCARBON SEAL KIT
			14-6205-01-X	14-6209-01-X	14-6213-01-X		
1	1	BUTTON HEAD CAP SCREW	21-4110-01	21-4100-09	21-4100-39	NO	NO
2	1	WIPER, ROD (FLUOROCARBON)	39-0530-04	39-0530-01	39-0530-00	YES	YES
3	1	BACK-UP RING, ROD	39-F540-00	39-F540-01	39-F540-02	YES	YES
4	1	SEAL, ROD (STANDARD)	39-0100-38	39-0100-20	39-0110-46	YES	NO
	1	SEAL, ROD (FLUOROCARBON)	39-0520-14	39-V100-20	39-V110-46	NO	YES
5	3	BALL, STEEL ALLOY	23-6000-14	23-6000-11	23-6000-02	YES	YES
6	3	BALL SEAT ASSEMBLY	90-1999-56	90-1999-57	90-1999-58	YES	YES
7	2	O-RING, ADAPTOR (STANDARD)	39-0500-36	39-0500-36	39-0500-36	YES*	NO
	2	O-RING, ADAPTOR (FLUOROCARBON)	39-0510-24	39-0510-24	39-0510-24	NO	YES*
8	2	MANIFOLD MOUNT ADAPTOR	30-8711-20	30-8711-20	30-8711-20	YES	NO
	2	MANIFOLD MOUNT ADAPTOR (FLUOROCARBON)	30-8711-20F	30-8711-20F	30-8711-20F	NO	YES
9	2	O-RING, MANIFOLD (STANDARD)	39-0500-42	39-0500-42	39-0500-42	YES*	NO
	2	O-RING, MANIFOLD (FLUOROCARBON)	39-0510-25	39-0510-25	39-0510-25	NO	YES*
10	1	PLUNGER, LEFT HAND (SHOWN)	81-4000-20	81-4000-19	81-4000-21	NO	NO
	1	PLUNGER, RIGHT HAND	81-4000-16	81-4000-17	81-4000-18	NO	NO
	1	PLUNGER, STRAIGHT	81-4000-72	81-4000-73	81-4000-74	NO	NO
11	1	SEAL, PLUNGER (STANDARD)	39-H100-37	39-H100-18	39-H110-30	YES	NO
	1	SEAL, PLUNGER (FLUOROCARBON)	39-V100-37	39-V100-18	39-V110-30	NO	YES
12	1	O-RING, RETAINER (FLUOROCARBON)	39-V000-36	39-0510-31	N/A	YES	YES
	1	GASKET	N/A	N/A	39-T550-03	YES	YES
13	1	RETAINER	81-4000-28	81-4000-29	81-4000-30	NO	NO
N/A	N/A	SEAL KIT (STANDARD)	60-1400-06	60-1400-08	60-1400-10	INCLUDED IN KIT	
N/A	N/A	SEAL KIT (FLUOROCARBON)	6V-1400-06	6V-1400-08	6V-1400-10		

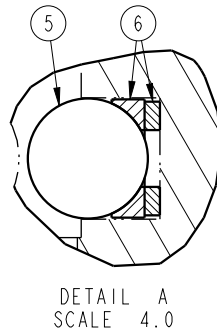

*NOTE: ITEMS INCLUDED IN NO. 8

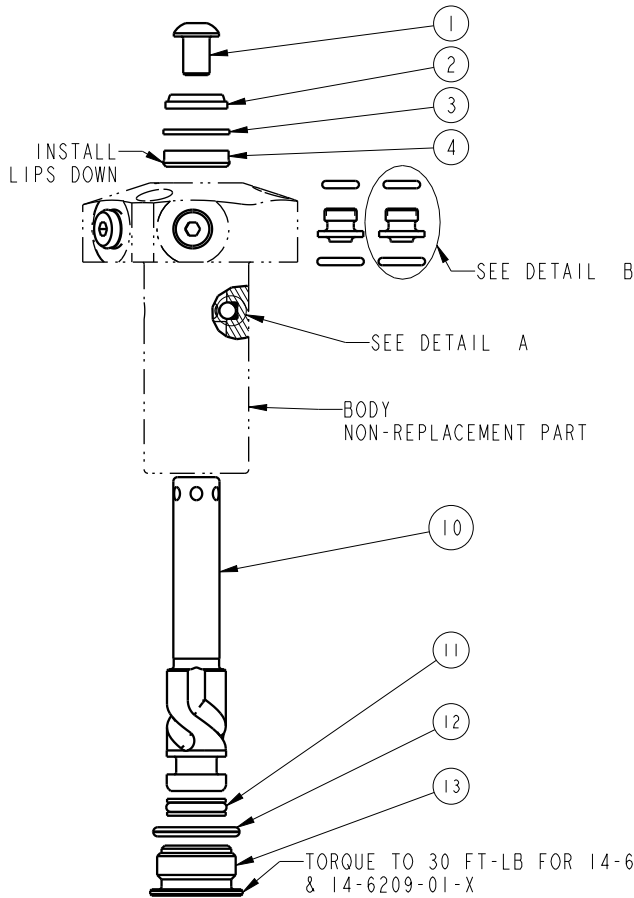
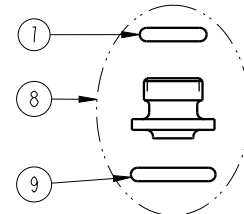

Lubricate all seals with clean hydraulic fluid prior to assembly.

PARTS LIST



VEKTEK, INC.
1334 E. SIXTH AVE. P.O. BOX 625
EMPORIA, KS. 66801 U.S.A.

ASSEMBLIES AFFECTED
14-6205-01-L, 14-6205-01-R, 14-6205-01-S
14-6209-01-L, 14-6209-01-R, 14-6209-01-S
14-6213-01-L, 14-6213-01-R, 14-6213-01-S

PARTS LIST, SC, TF, HS, DA

SIZE A
PLI411

REV H

H	5279	RELEASE	ALS	4/18/24
REV	IN ACCORDANCE WITH ECN	EFFECTIVE DATE	REVISED BY	DATE
DRW BY:	KWR	DRAWING STATUS: Released		
DATE:	11/08/04	PRODUCTION APPROVED FOR RELEASED STATUS ONLY		